

# Model No. HM0810T DEMOLITION HAMMER

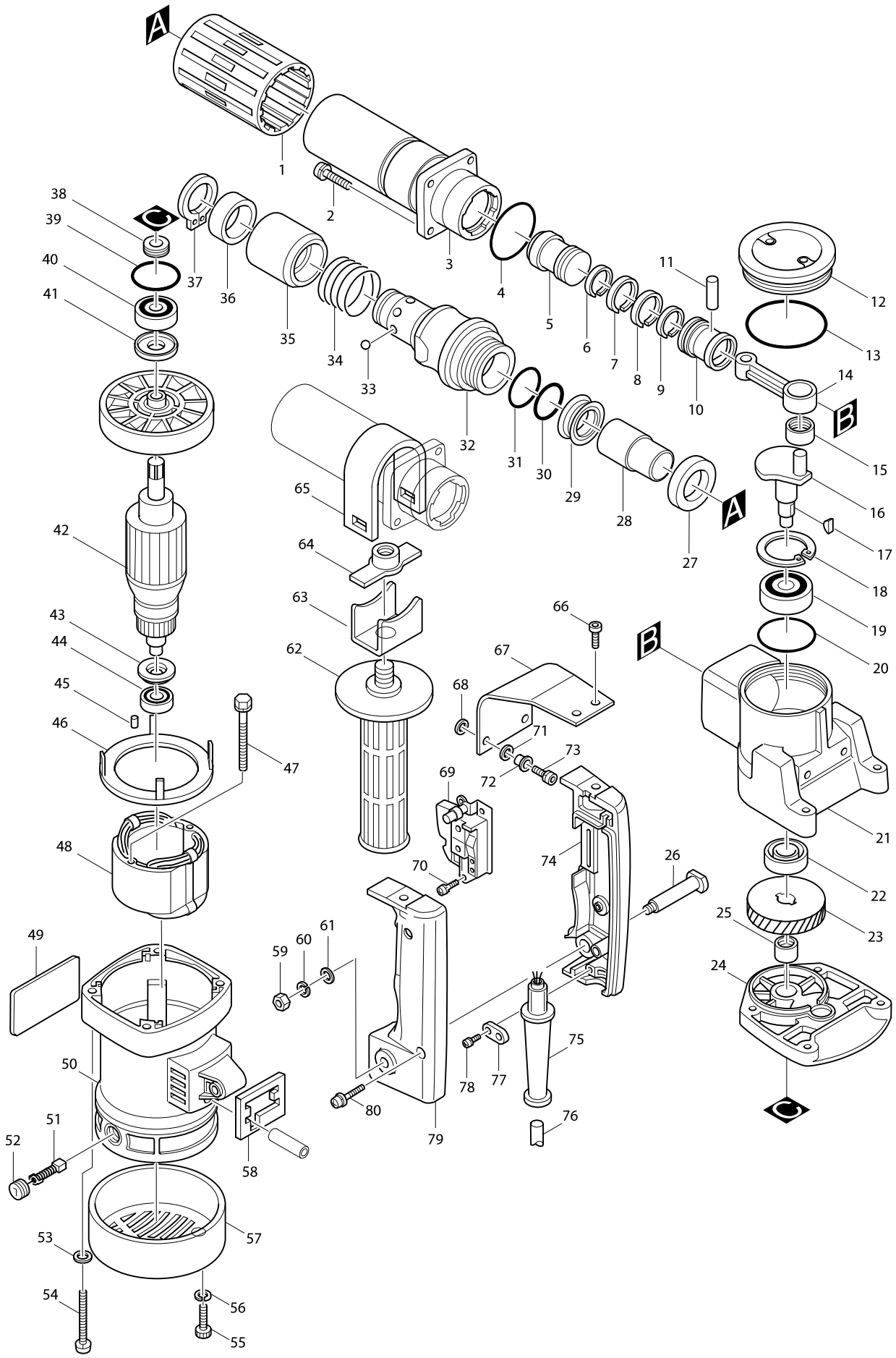

# Model No. HM0810T DEMOLITION HAMMER

Item	Parts No.	Description	I/C	QTY	N/O	Opt. 1	Opt. 2	NOTE
001	421541-7	BARREL COVER		1				
002	922341-3	HEX. SOCKET HEAD BOLT M6X25		4				
003	151457-9	BARREL COMPLETE		1				
004	213554-0	O RING 44		1				
005	321929-0	STRIKER		1				
006	412073-5	INNER RING 26		1				
007	412053-1	PISTON RING 30		1				
008	412053-1	PISTON RING 30		1				
009	321514-9	INNER RING 26		1				
010	321958-3	PISTON		1				
011	256165-8	PIN 8		1				
012-1	411709-3	CRANK CAP	O	1				
013	213654-6	O RING 60		1				
014	312956-8	ROD		1				
015	212108-0	NEEDLE BEARING 1212		1				
016	321954-1	CRANK SHAFT		1				
017	254001-2	WOODRUFF KEY 4		2				
018	962203-3	RETAINING RING R-47		1				
019	211279-0	BALL BEARING 6303LLU		1				
020	213606-7	O RING 48		1				
021	157627-8	CRANK HOUSING COMPLETE		1				
D10		INC. 20						
022	213260-7	OIL SEAL 17		1				
023	221669-9	HELICAL GEAR 41		1				
024	157628-6	GEAR HOUSING		1				
D10		INC. 39						
025	212102-2	NEEDLE BEARING 1210		1				
026	321210-9	HANDLE SHAFT		1				
027	253955-0	FLAT WASHER 24		1				
028	321495-7	IMPACT BOLT		1				
029	213428-5	X RING 28		1				
030	213411-2	O RING 27		1				
031	213508-7	O RING 38		1				
032	125070-9	TOOL HOLDER ASS'Y		1	*			
D10		INC. 33-36,37			*			
032-1	193004-0	TOOL HOLDER SET	X	1				
D10		INC. 31,33-37,81						
033-1	216004-4	STEEL BALL 7.9		6				
034	233191-4	COMPRESSION SPRING 30		1				
035	331518-3	CHANGE RING		1				
036	257206-3	RING 29		1				
037	962106-1	RETAINING RING R-28		1	*			
037-1	961108-4	RETAINING RING S-28	X	1				
038	331194-3	SEAL		1				
039	213459-4	O RING 32		1				
040	211106-1	BALL BEARING 6201LLB		1	*			
040-1	211144-3	BALL BEARING 6201LLB	O	1	*			
040-2	211106-1	BALL BEARING 6201LLB	O	1				

# Model No. HM0810T DEMOLITION HAMMER

Item	Parts No.	Description	I/C	QTY	N/O	Opt. 1	Opt. 2	NOTE
041	213102-5	DUST SEAL 12		1				
042B_	516148-3	ARMATURE ASS'Y 220V		1	*			
C10	241827-1	FAN 82		1	*			
D10		INC. 40,41,43,44			*			
042B1	516148-3	ARMATURE ASS'Y 220V	O	1				
C10	241827-1	FAN 82		1				
D10		INC. 40,41,43,44						
043	681625-5	INSULATION WASHER		1				
044	211031-6	BALL BEARING 608LLB		1				
045	263014-2	RUBBER PIN 4		1	*			
045-1	263002-9	RUBBER PIN 4	O	1				
046	410509-8	BAFFLE PLATE		1				
047	265345-5	+ HEX. BOLT M5X60		2				
048B_	522508-9	FIELD ASS'Y 220V		1				
C10	654019-7	RING TERMINAL		2				
C20	654501-6	CONNECTOR P-1.25		2				
049	858893-7	NAME PLATE HM0810T		1	*			
049-1	897974-2	NAME PLATE HM0810T	<	1				
050	159634-7	MOTOR HOUSING		1				
C10	643603-3	BRUSH HOLDER 6-10		2				
D10		INC. 45						
051	181038-5	A.C. CARBON BRUSH CB-105		1	*			
051-1	194975-4	CARBON BRUSH SET CB-105	<	1				
052	643600-9	BRUSH HOLDER CAP 6-10		2				
053	941151-9	FLAT WASHER 6		4	*			
054	922371-4	HEX. SOCKET HEAD BOLT M6X50		4	*			
054-1	922374-8	H.S.H.BOLT M6X50 WITH WG	S	4				
055-1	922226-3	HEX. SOCKET HEAD BOLT M5X18		2				
056	942101-7	SPRING WASHER 5		2	*			
057	284059-7	REAR COVER		1				
058	423257-0	SPONGE 38.5-46		1				
059	931302-2	HEX. NUT M6		1				
060	942151-2	SPRING WASHER 6		1				
061	941151-9	FLAT WASHER 6		1				
062	273457-0	GRIP 32		1				
063	341922-8	GRIP BASE		1				
064	321497-3	CLAMP NUT		1				
065	341914-7	GRIP CLAMP		1				
066	922316-2	HEX. SOCKET HEAD BOLT M6X14		2				
067	343753-1	CUSHION PLATE		2				
068	262051-3	RUBBER RING 9		2				
069	651051-2	SWITCH HPAHR6-35S		1				
070	911109-2	PAN HEAD SCREW M4X8		2				
071	262052-1	RUBBER RING 9		2				
072	257636-8	SLEEVE 6		2				
073	265914-2	HEX. SOCKET HEAD BOLT M6X25		2				
074	182590-6	HANDLE SET		1				
D10		INC. 79						

